

SINPHOS

SINGLE PHOTON SPECTROMETER FOR BIOMEDICAL APPLICATION

Salvatore Tudisco

**9th Topical Seminar on Innovative Particle and Radiation Detectors
23 - 26 May 2004 Siena, Italy**





Delayed Luminescence

In the last decades several experiments have clearly demonstrated that, once illuminated, all biological system emit for a quite long range (up to seconds) a very weak flux of photons, called DL

- ⌘ Firstly observed from plant by Arnold and Strehler in 1950
- ⌘ 10^3 ? 10^5 times lower in intensity than the fluorescence

Delayed luminescence is less popular than fluorescence:

- ⌘ Delayed Luminescence is by nature extremely polyphasic; the lifetime spectrum extends from 10^{-7} to more than 10 s
- ⌘ Delayed Luminescence is inherently a low-level signal

Delayed Luminescence

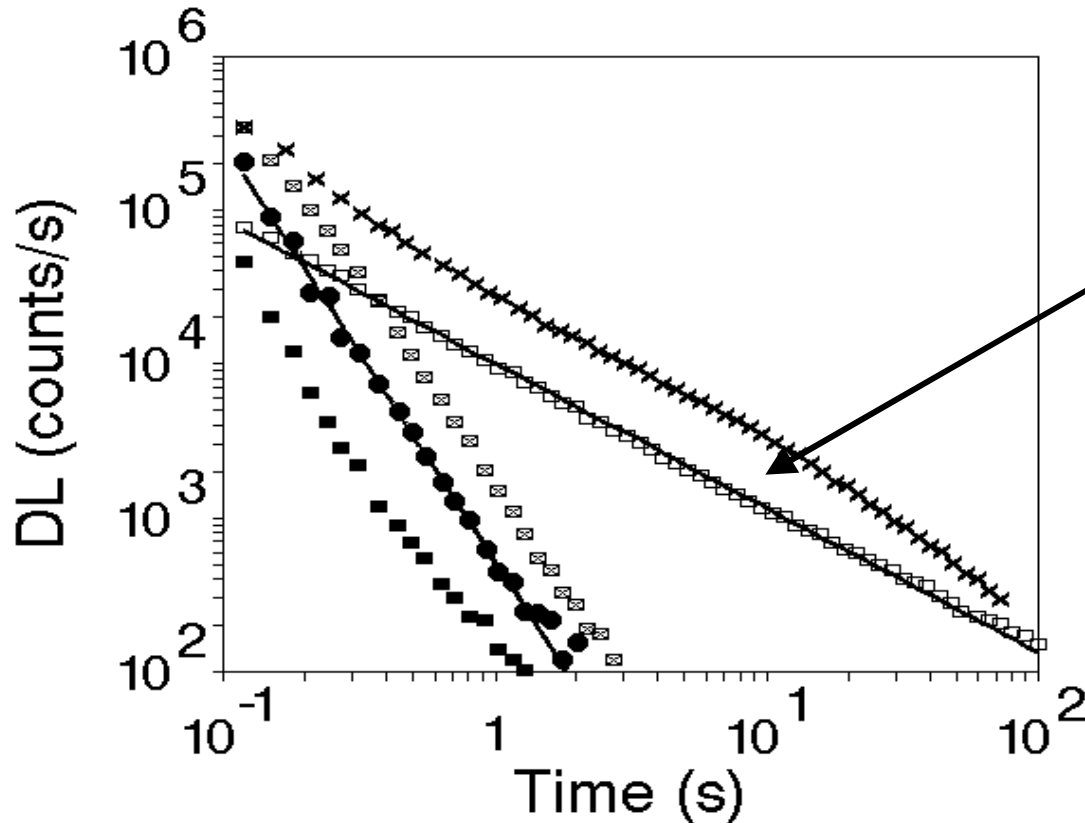

DL kinetics correspond to the hyperbolic trend

$$I(t) \approx \frac{I_0}{(1 + t/t_0)^m}$$

m = Slope

(●) yeast culture, (■) *Acetabularia acetabulum*, (×) soya seeds, (□) pepper seeds, (○) tomatoes
 400 < λ < 450 nm.

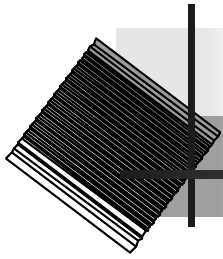

Delayed Luminescence

- DL is a sensitive indicator of the biological state of the system
- DL can be a powerful tool for **medical investigations, food and water quality control**, etc

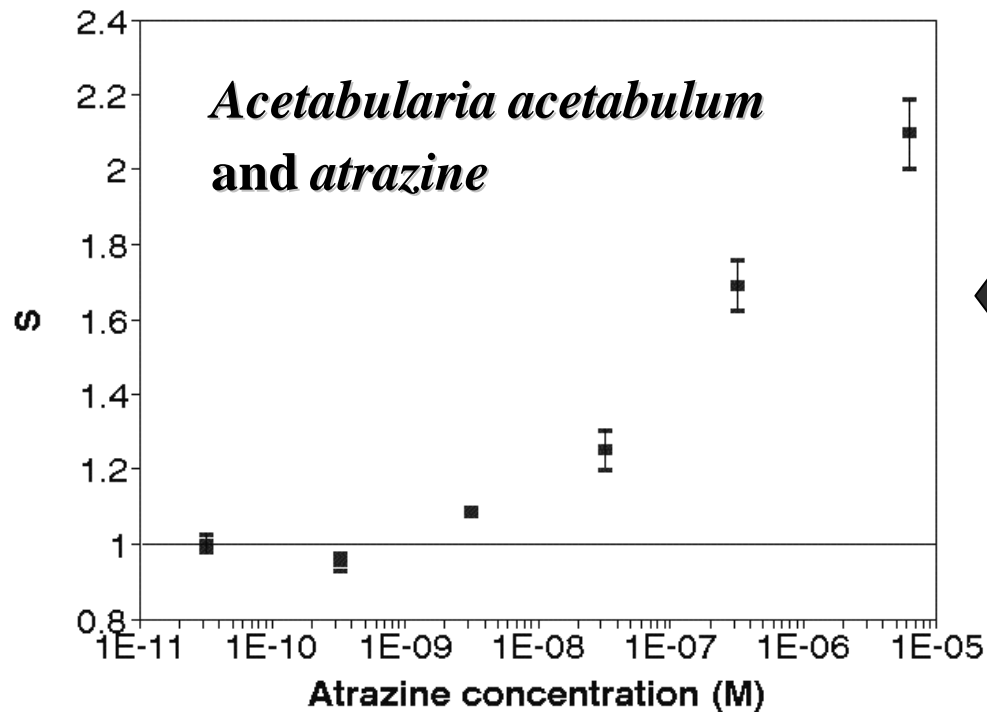

$$S = m/m_0$$

← **Biological detector
for water pollution**

Biomedical Application of DL

Recent experimental results: →

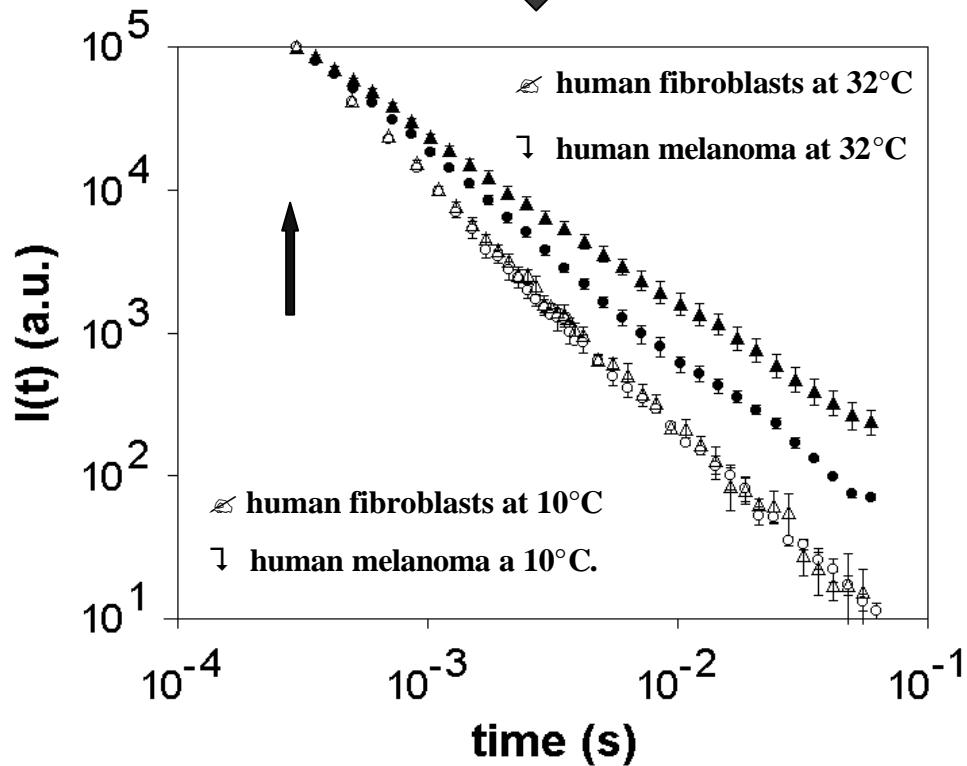

DL time trend of human cells at several temperatures

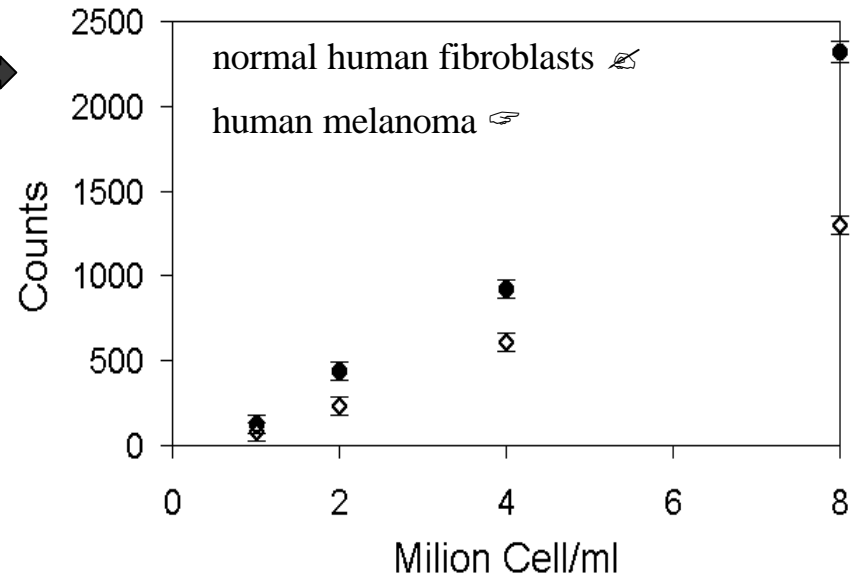

Total DL photons as a function of the cell density

Detection system:

- Single photon counting
- Low background noise

Biomedical Application of DL

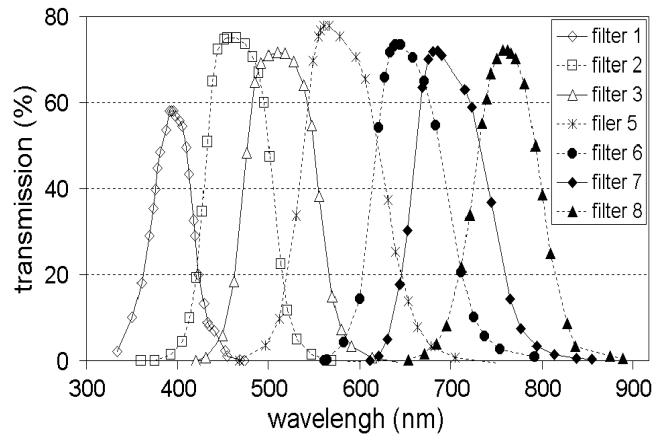
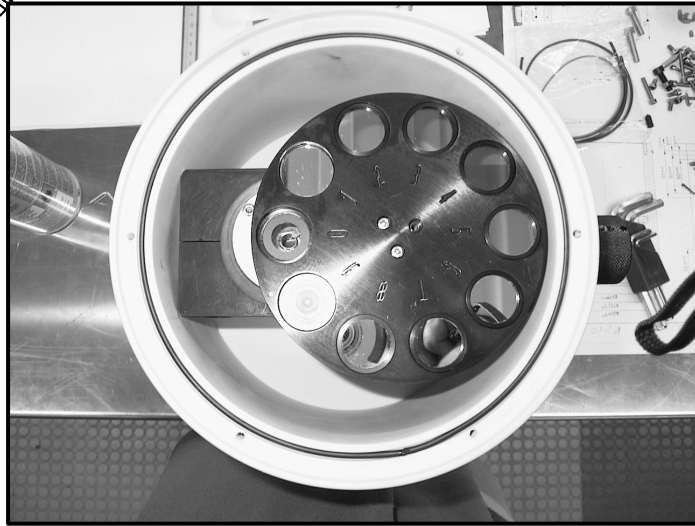

S.Tudisco et al. NIM A 518 (2004) 463

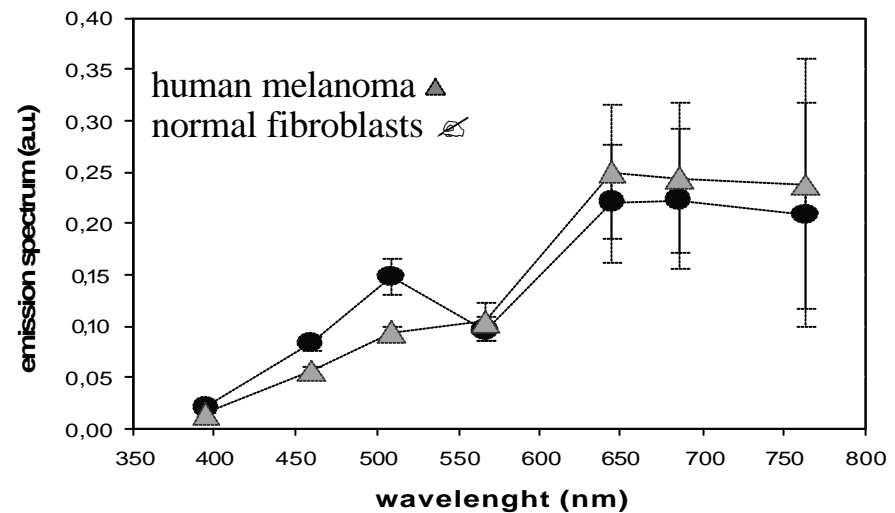
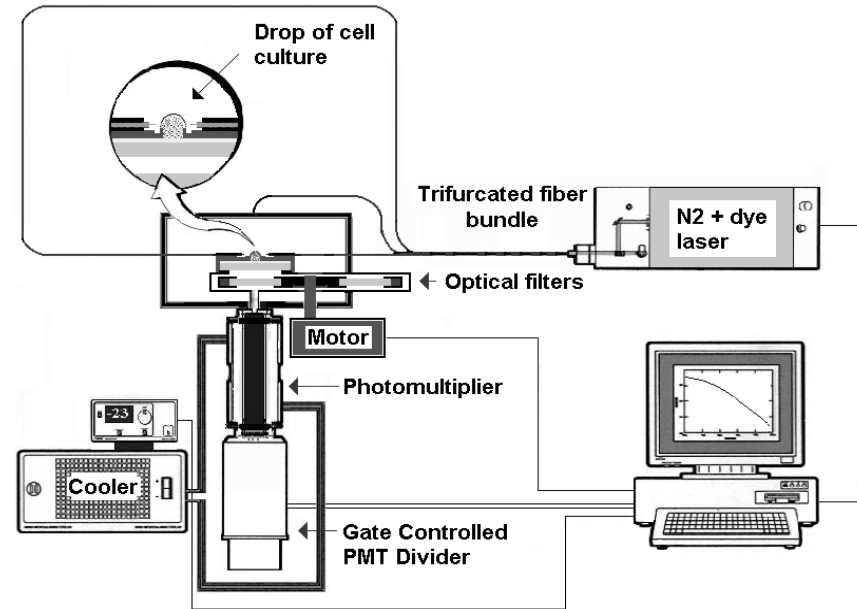

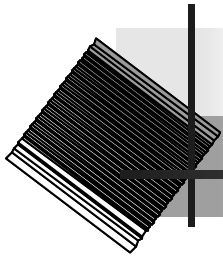

SINPHOS: SINGle PHOton Spectrometer

Activity supported by INFN - V national committee

Partner:

- ✧ **ST- Microelectronics**
- ✧ **Applied Physics and Photonics Department of Bruxelles University (VUB)**

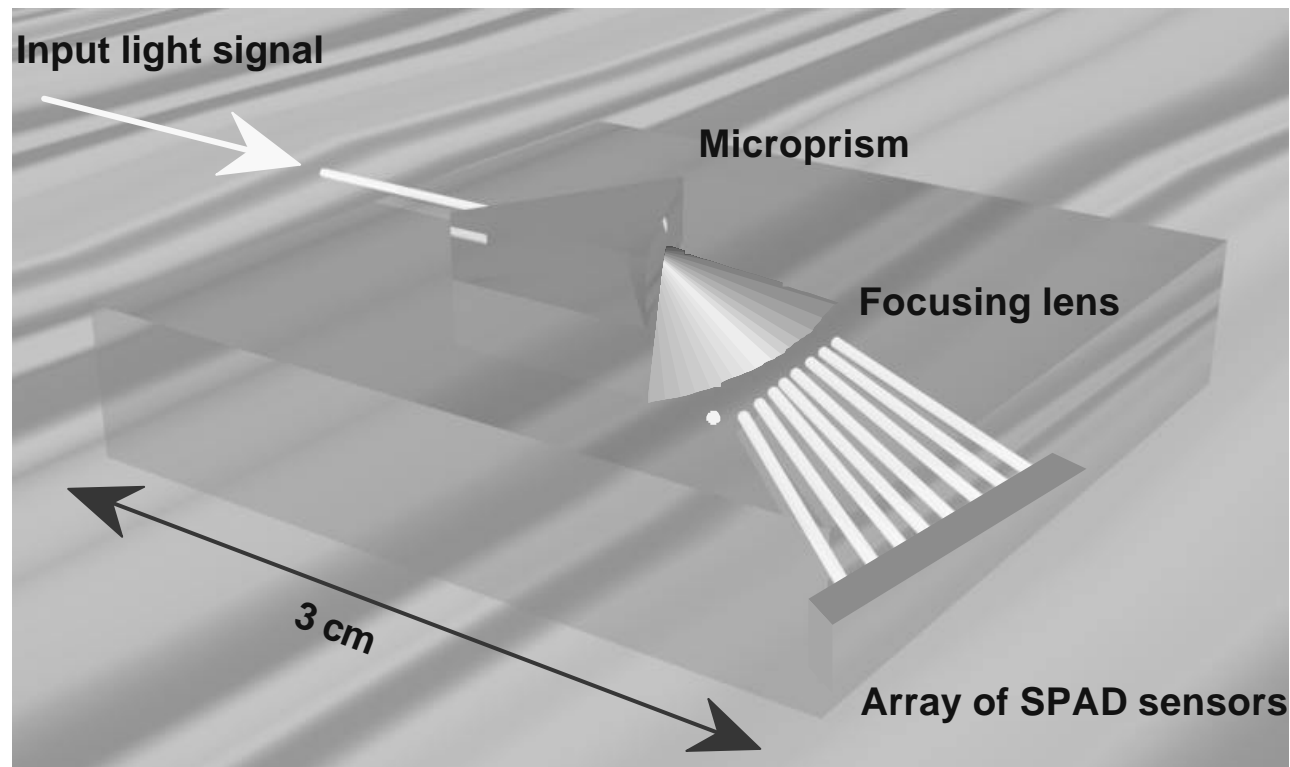

DLP: Deep Lithography with Particles beam

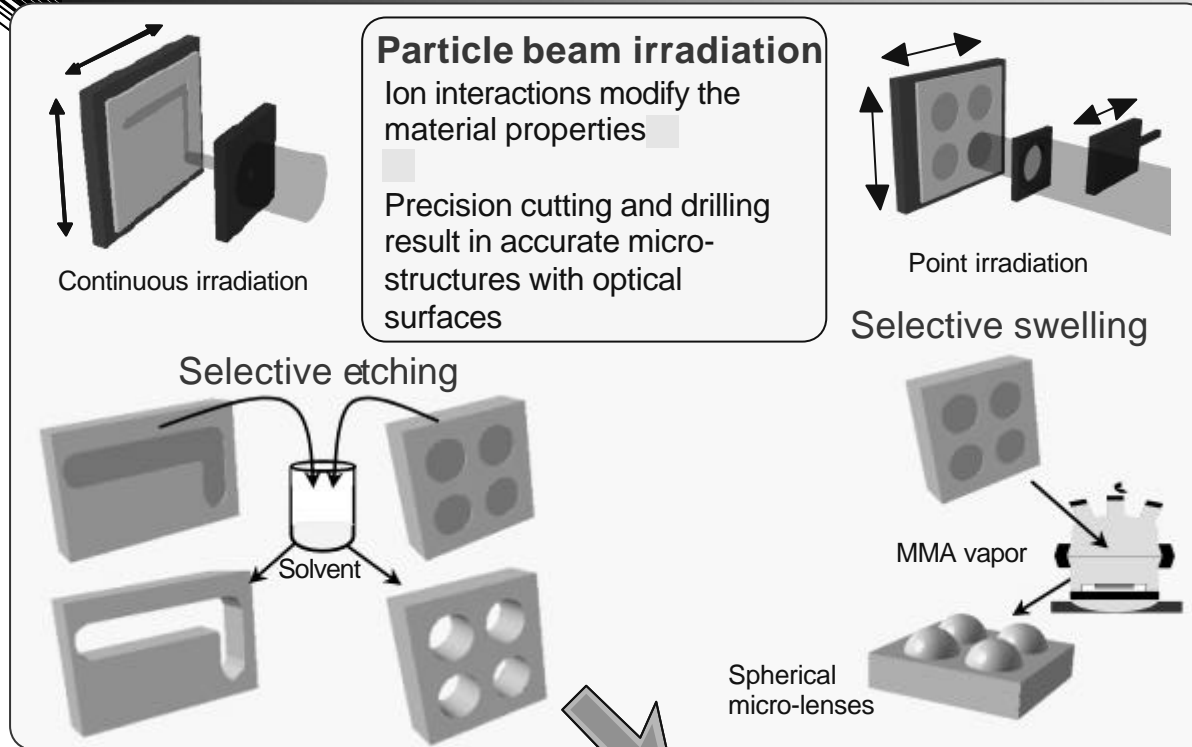

2D spherical micro-lens arrays

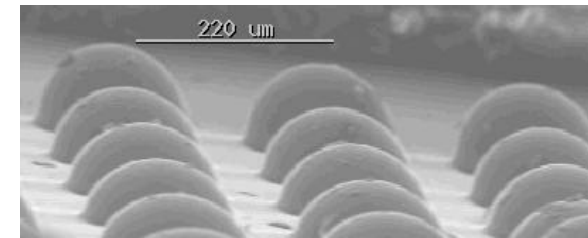

2D fiber holders

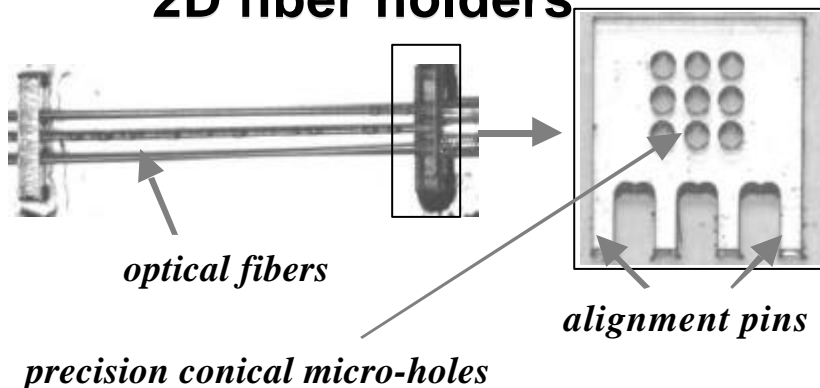

The fabrication process consists of three basic procedure: ion irradiation of a PMMA substrate followed by a development of the irradiated regions with a selective solvent or by volume expansion of the bombarded zones caused by a diffusion of an organic monomer vapor.

L.Cosentino et al., NIM B 209(2003)340.

DLP: Preliminary Results

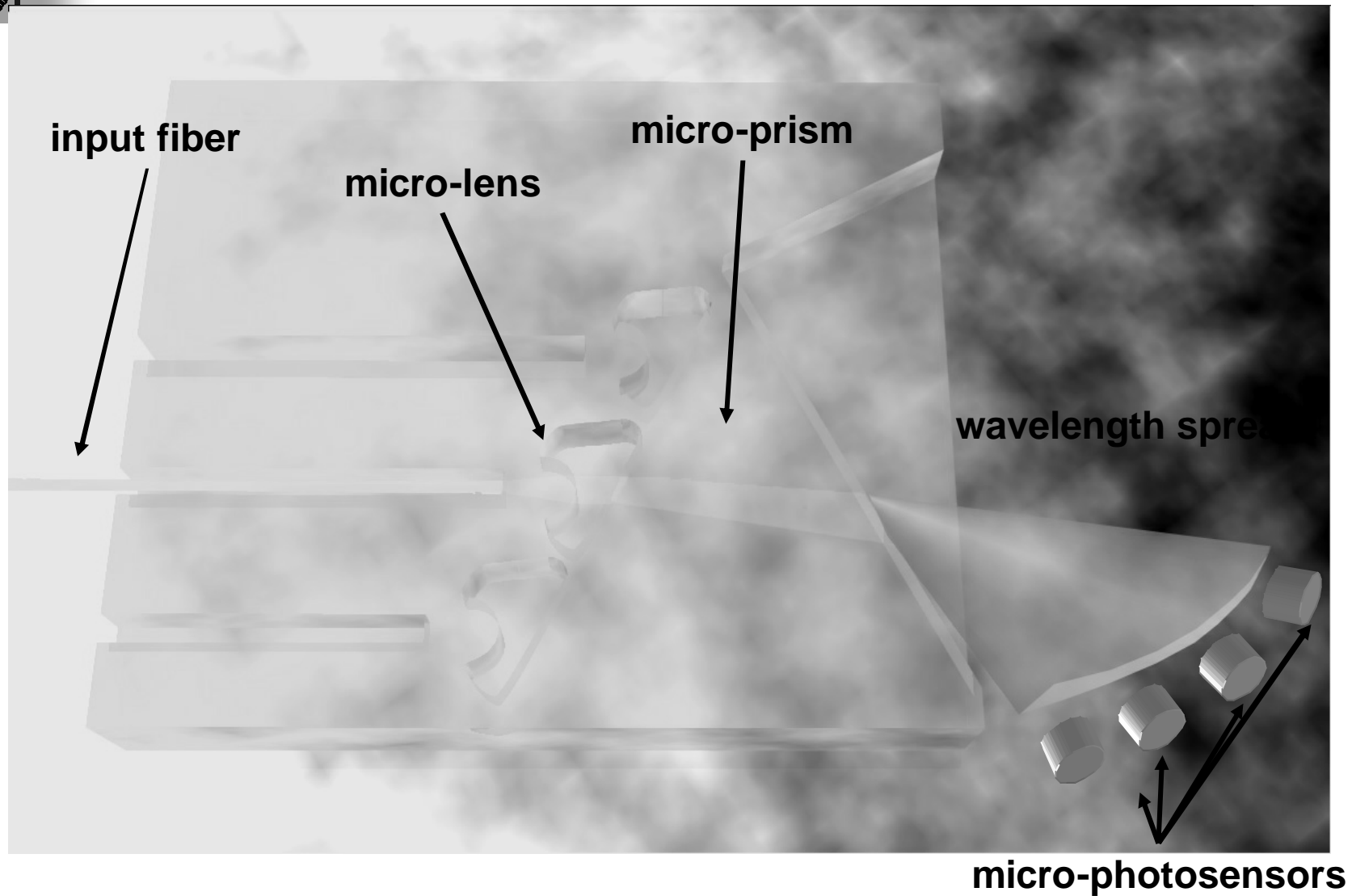

DLP: Preliminary Results

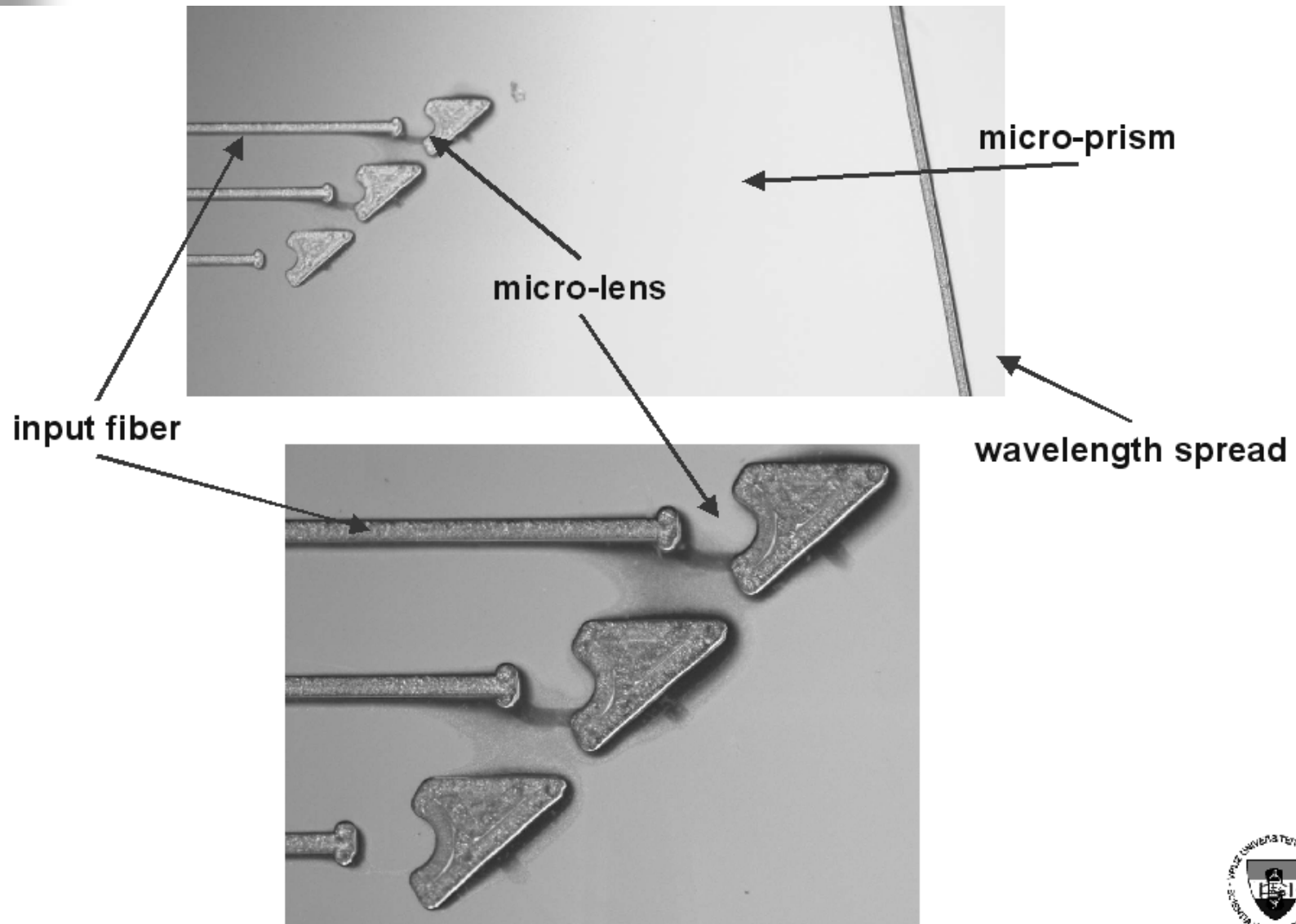

SPAD - Single Photon Avalanche Detector

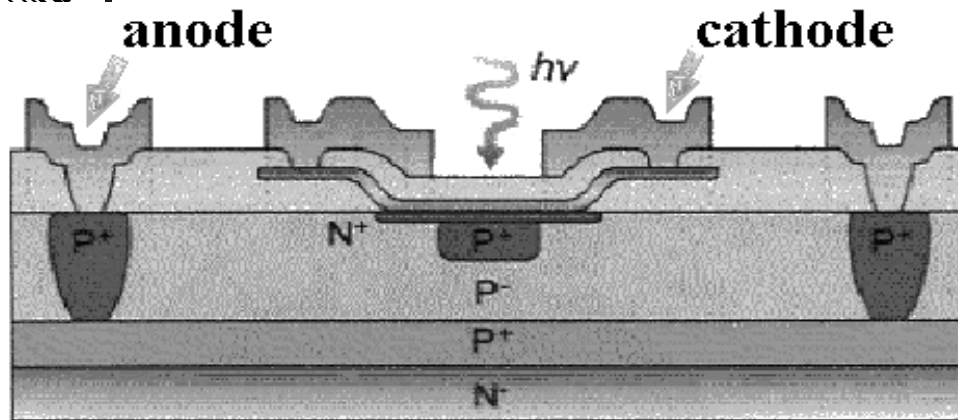

ST - Microelectronics

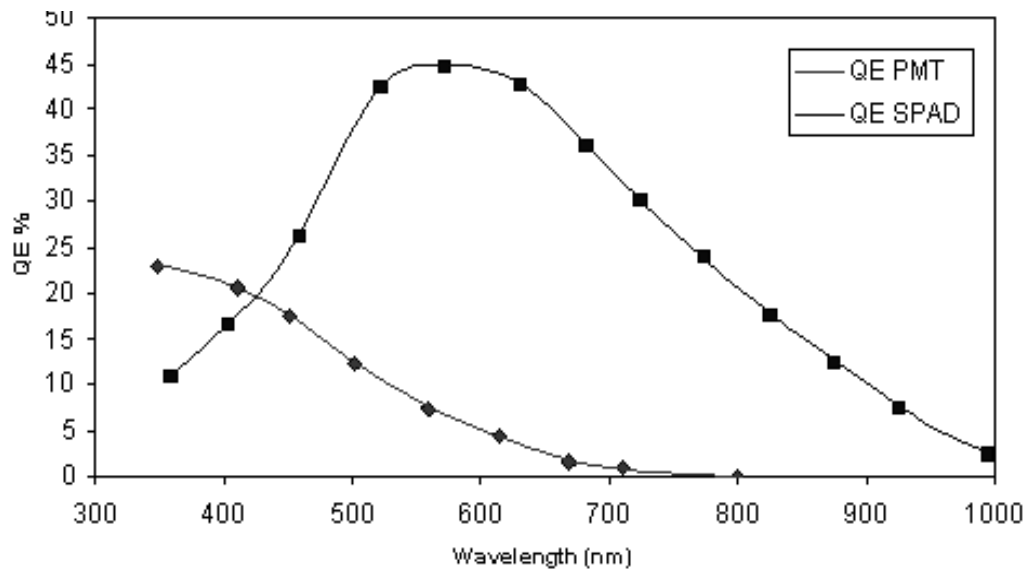

- Developed by ST Microelectronics
- Compact (10-100 μ m) and reliable
- 100 ps timing
- High quantum efficiency
- Can be built in form of arrays
- Can be coupled to micro-optical devices built by means of DLP

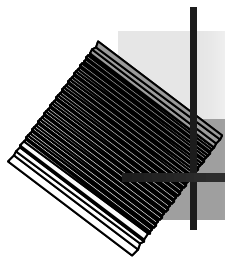

SPAD

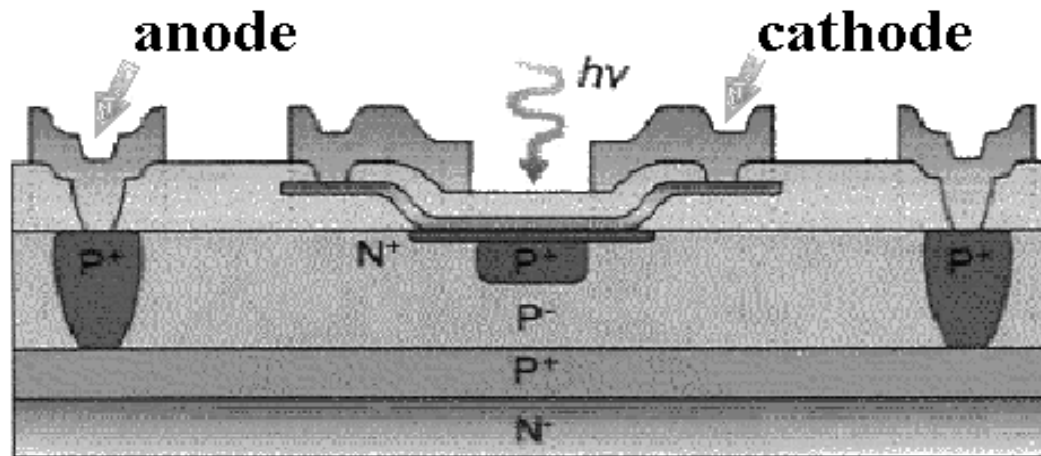

p-n junction remaining quiescent above breakdown voltage until a photon is absorbed in the depletion volume

- The event is detected through an avalanche current pulse
- Low operating voltage 30 Volts
- Average gain for each photocarrier is about 10^6
- Dark counting rates at room temperature: 10c/s for 10 μ m device and 1kc/s for 50 μ m

SPAD: Readout

Passive quenching circuit

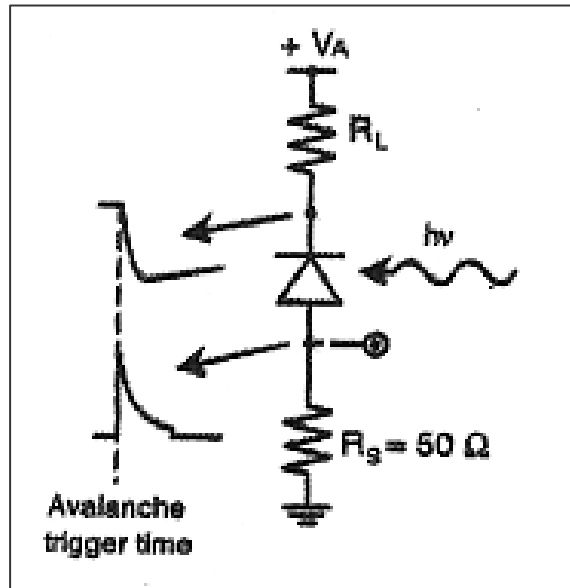

In the passive mode the spad is reversed biased trough a resistor of 100 k ohm or more. One can obtain an output pulse from a PQC, by inserting a low value resistor R_s in series on the ground of the circuit. When the avalanche is generated it discharges the junction capacitance and the diode voltage fall down exponentially restoring the quiescent state

Active quenching circuit

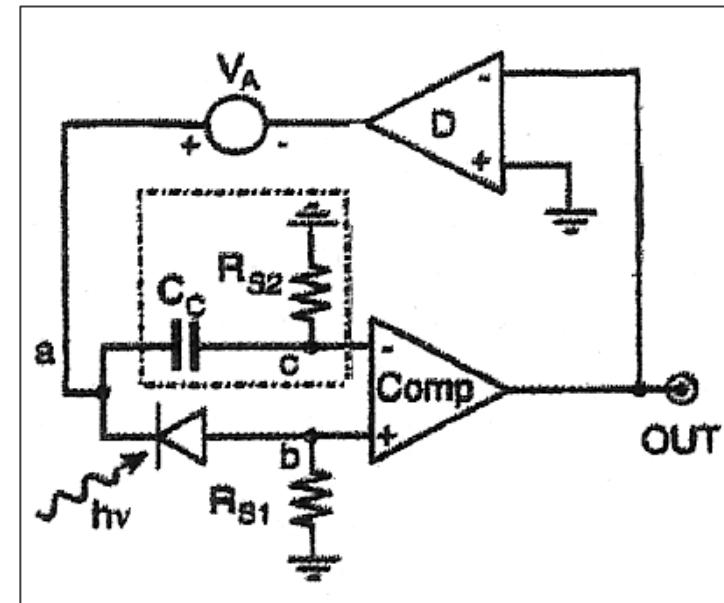

In the active mode a circuit senses the rise of avalanche pulse and react back on the spad forcing with e controlled bias source the quenching and the reset transitions in short times

Time Correlated Single Photon Counting measurement

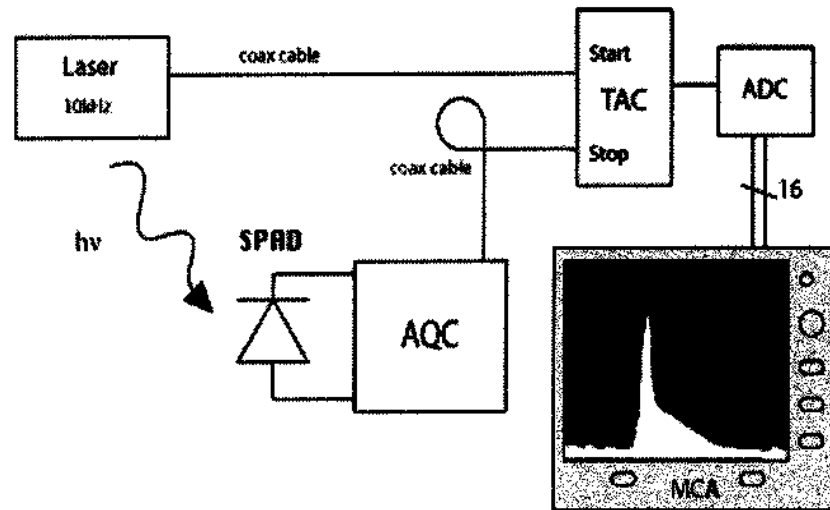

- Optical pulses:**
- 820 nm
 - FWHM 20 ps
 - 10 kHz repetition rate

**Photons absorbed in the depletion region
Minority carriers photogenerated in the
neutral p region that reach the junction
by diffusion**

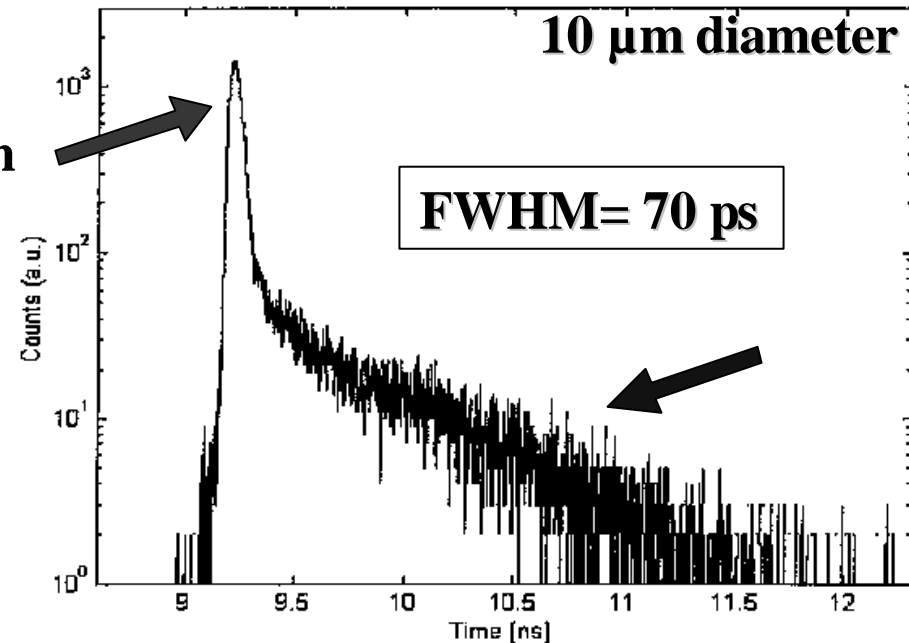
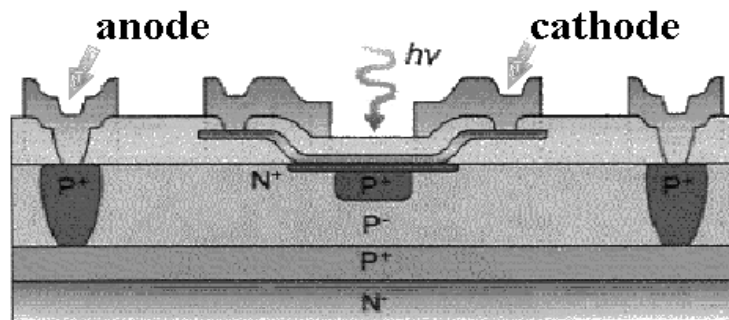

Scintillator readout with SPAD

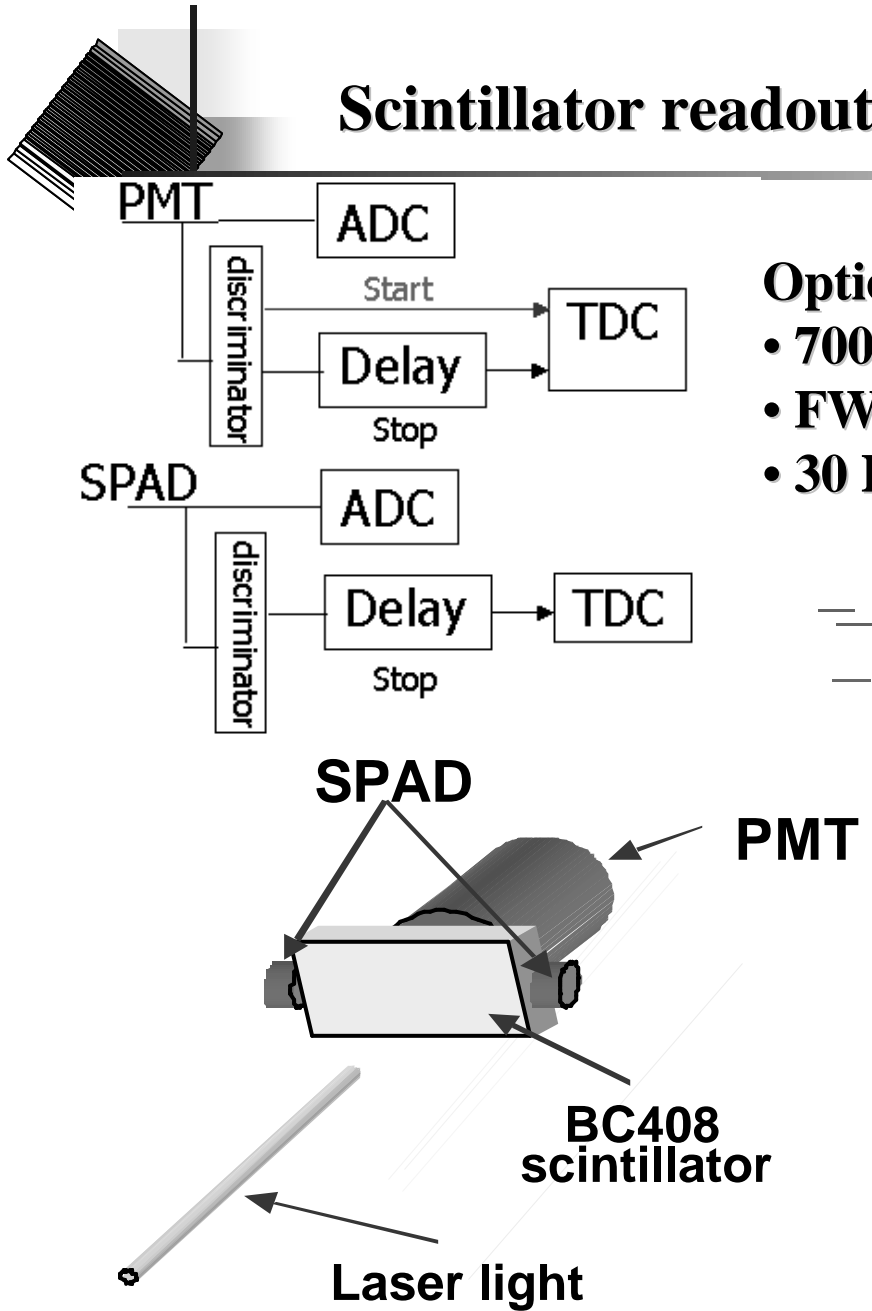

Optical pulses:

- 700 nm
- FWHM 2 ns
- 30 Hz repetition rate

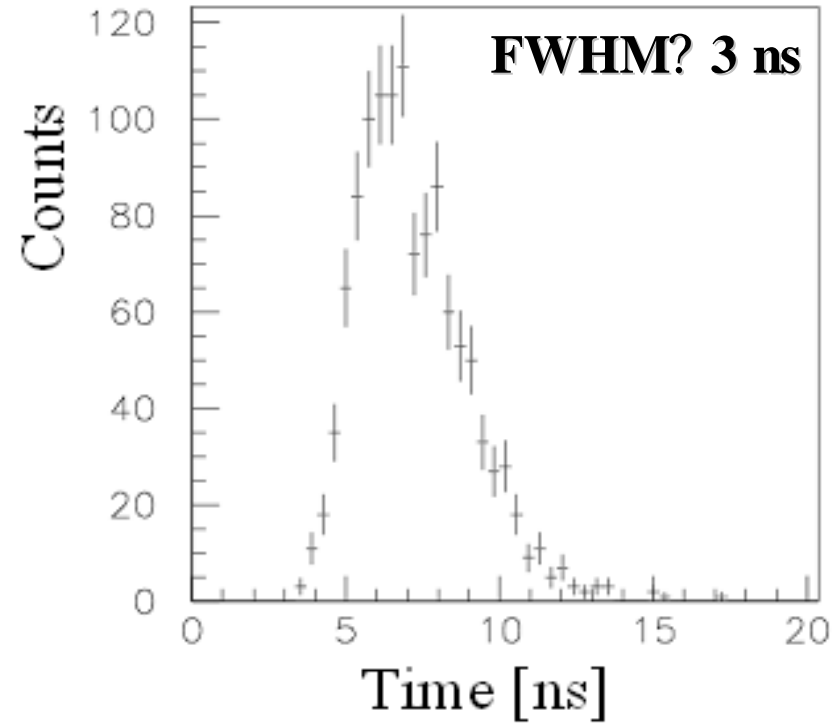
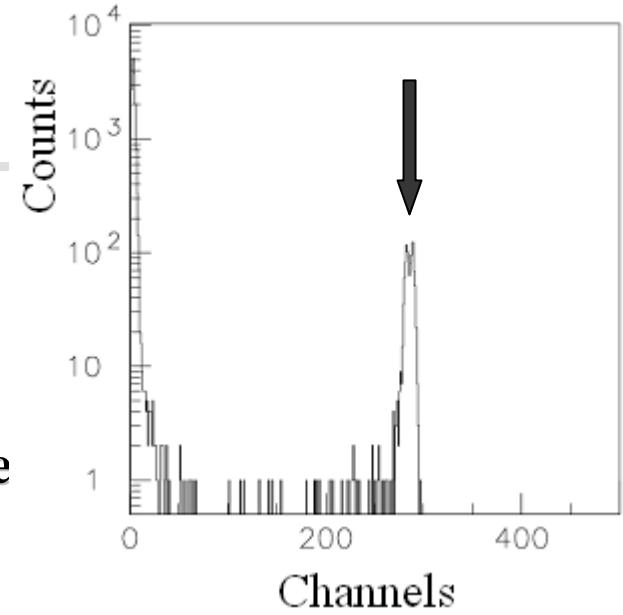

Scintillator readout with SPAD

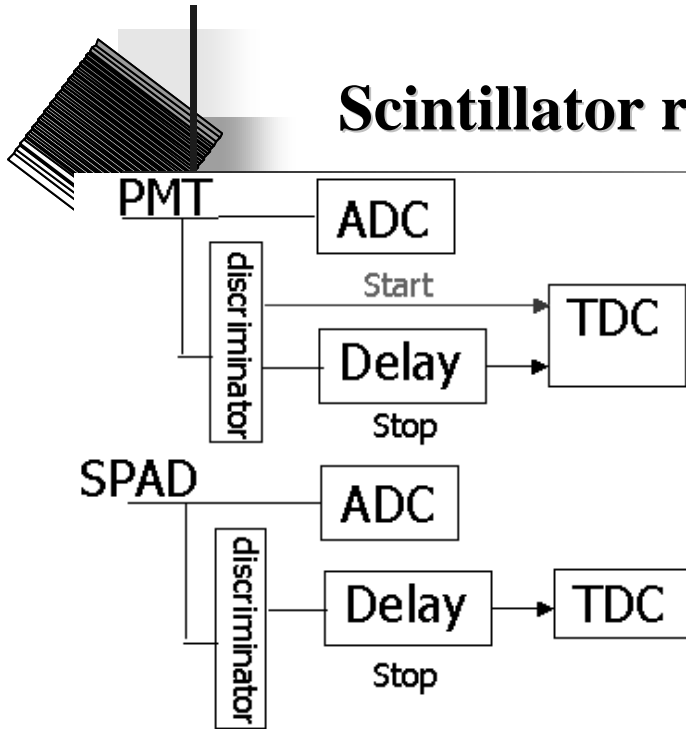

BC408:

- 420 nm
- mean life 2.1 ns

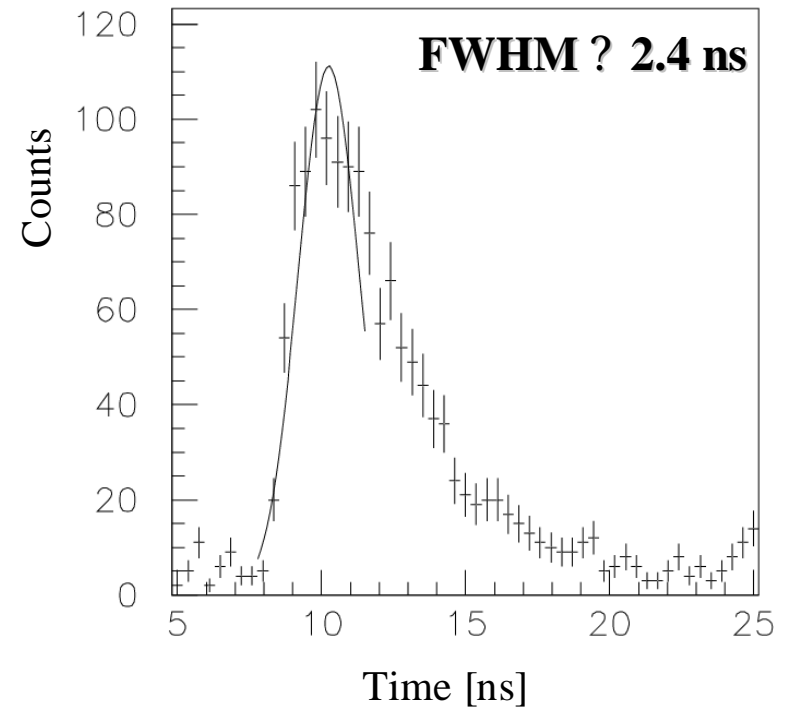
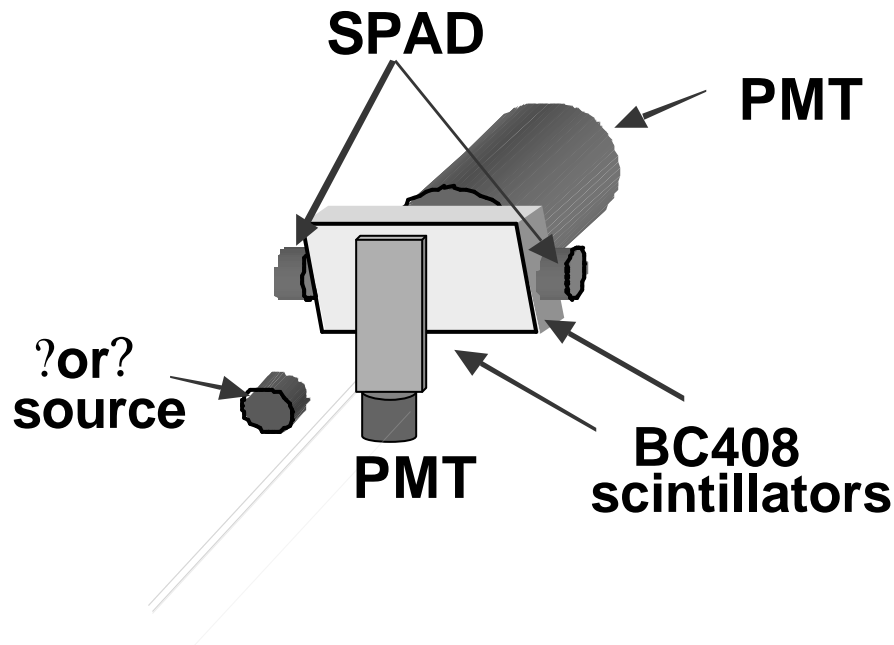

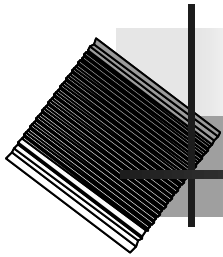

Summary

- ✎ **DLP** – first results confirms the possibility to use such a technique to develop an optical custom device for the SINPHOS spectrometer.
- ✎ **SPAD** - the measurement performed by using e passive quenching read-out have confirmed the results obtained with an active read-out system. Time resolution as expected is a little worst but fully sufficient for biomedical application purpose.
- ✎ **Linear array** – starting from the concrete possibility to use passive quenching, a read-out system for a whole linear array has been studied and should be tested soon.

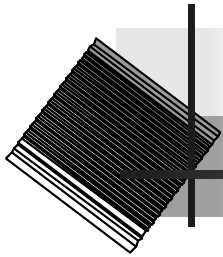

Collaboration

INFN-LNS

Catania University

S. Tudisco

G. Cosentino

P. Finocchiaro

F. Musumeci

A. Scordino

G. Privitera

S. Privitera