

Measuring the electron neutrino mass with improved sensitivity

The HOLMES experiment

Andrea Giachero

on behalf on the HOLMES collaboration

INFN Milano-Bicocca



Direct neutrino mass measurements

Kinematics of weak decays with ν emission:

- Only energy and momentum conservation;
- No further assumptions;
- Low Q nuclear beta decays (${}^3\text{H}$, ${}^{187}\text{Re}$, ${}^{163}\text{Ho}$);

Two approaches with different:

- **Spectrometry:** the β source is outside the spectrometry detector;
- **Calorimetry:** the β source is contained in the calorimetry detector which measures all the energy released except the ν energy.

Spectrometry: KATRIN

Large MAC-E filter spectrometer with ${}^3\text{H}$ source [1, 2]

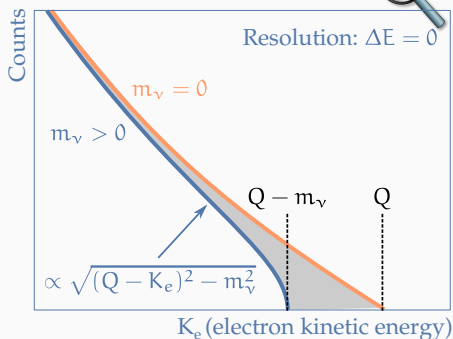
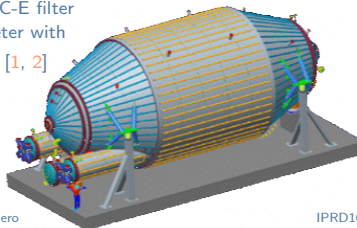

Calorimetry: Mare, ECHo, Holmes, NuMECS

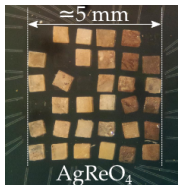

Array of low temperature microcalorimeters with ${}^{187}\text{Re}$ [3, 4] or ${}^{163}\text{Ho}$ [5]



An interesting isotope suitable for the neutrino mass experiment is the ^{163}Ho .



proposed by A. De Rujula e M. Lusignoli in 1982 [6, 7]

- Calorimetric measurement of Dy atomic de-excitations (mostly non-radiative):
⇒ measurement of the entire energy released except the ν energy;
- Lower is the Q-value higher is the rate at end-point;
- Q_{EC} and atomic de-excitation spectrum poorly known:
⇒ Measured $Q_{EC} = 2.833 \text{ keV}$ with Penny Trap mass spectroscopy [8];
⇒ But no calorimetric measurements with enough statistics at the end point;
- $\tau_{1/2} \simeq 4570 \text{ years}$ ⇒ high specific activity:
⇒ Holmium detector not needed;
⇒ ^{163}Ho can be implanted in any suitable microcalorimeter absorber;
- Complex pile-up spectrum;
- **Assessment of Q-value from the end-point of the calorimetric spectrum is a primary goal.**

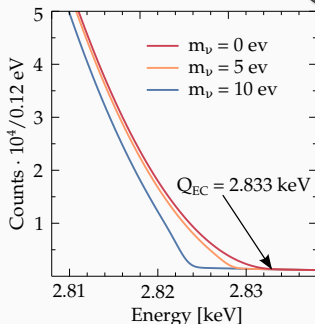
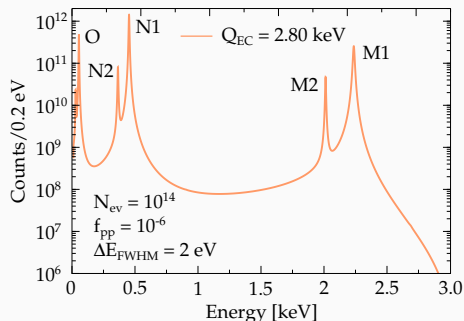

$$\frac{d\lambda_{EC}}{dE_c} = \frac{G_\beta^2}{4\pi^2} (Q_{EC} - E_c) \sqrt{(Q_{EC} - E_c)^2 - m_\nu^2} \cdot \sum_i n_i C_i \beta_i^2 B_i \frac{\Gamma_i}{2\pi} \frac{1}{(E_c - E_i)^2 + \Gamma_i^2/4}$$

- Continuum with marked peaks with Breit-Wigner shapes lines (width Γ_i of a few eV);
- Series of lines at the ionization energies E_i of the captured electrons;
- End-point shaped by $\sqrt{(Q - E_e)^2 - m_\nu^2}$ (the same of the β -decay);
- Self calibrating spectrum;

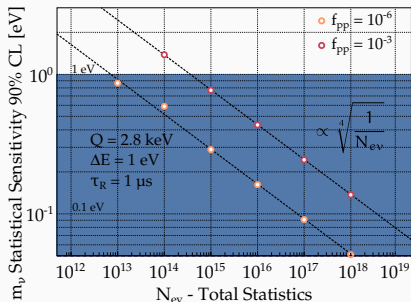

A. Nucciotti, Eur. Phys. J. C 74 (2014) 3161 [9]

$$m_\nu \leq 0.1 \text{ eV: } \left\{ \begin{array}{l} A_{EC} = 1 \text{ Bq} \\ N_{det} \cdot t_{meas} \simeq 2 \cdot 10^9 \text{ det} \cdot \text{years} \\ A_{EC} = 1000 \text{ Bq} \\ N_{det} \cdot t_{meas} \simeq 10^8 \text{ det} \cdot \text{years} \end{array} \right.$$

Requirements for $m_\nu \leq 0.1 \text{ eV}$

- High energy resolution ($\simeq 1 \text{ eV}$);
- Fast response detectors ($\simeq 1 \mu\text{s}$) to avoid pile-up events;
- Multiplexable detectors array ($N_{pixel} > 1000$ [10, 11]);



Low Temperature Detector



TESs, MMCs, MKIDs, ...

Current calorimetric limit is

$$m_\nu \leq 15 \text{ eV (90% C.L.)} [3, 4]$$

with ^{187}Re isotope



Goal

- Prove technique potential and its scalability
⇒ baseline for a future Megapixel experiment;
- Neutrino mass measurement:
⇒ statistical sensitivity $m_\nu < 2 \text{ eV}$;
- Assess EC Q-value with a long calorimetric measurement;
- Assess systematic errors;



Baseline

- Transition Edge Sensors (TES) with ^{163}Ho implanted Au absorbers;
- $6.5 \cdot 10^{13}$ nuclei/detector (18 μg in total) \Rightarrow 300 dec/s/pixel;
- $\Delta E \simeq (2 - 5) \text{ eV}$ and $\tau_{\text{rise}} \simeq 10 \mu\text{s}$;
- 64-channel demonstrator/1024-channel final array;
- $3 \cdot 10^{13}$ events in 3 years of data taking;



Project Start: 1 Feb 2014

<http://artico.mib.infn.it/nucrimib/experiments/holmes>

B. Alpert *et al.*, The European Physical Journal C, vol. **75**, 112 (2015) [12]



Neutron activation of enriched ^{162}Er

$$^{162}\text{Er}(n, \gamma)^{163}\text{Er} \quad \sigma_{therm} = 20 \text{ b}$$

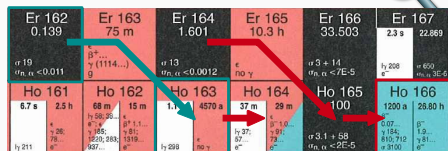

- ^{132}Er irradiation at ILL (Institut LaueLangevin) nuclear reactor (Grenoble, France);
 - ⇒ Thermal neutron flux at ILL: $1.3 \cdot 10^{15} \text{ n/cm}^2/\text{s}$;
 - ⇒ Unavoidable burn up $^{163}\text{Ho}(n, \gamma)^{164}\text{Ho}$: $\sigma_{burn-up} \simeq 200 \text{ b}$ (preliminary result from PSI analysis);
 - ⇒ Unavoidable $^{165}\text{Ho}(n, \gamma)$, mostly from $^{164}\text{Er}(n, \gamma) \rightarrow ^{166m}\text{Ho}(\beta, \tau_{12} = 1200 \text{ y})$:
 $A(^{163}\text{Ho}) / A(^{166m}\text{Ho}) = 100 - 1000$
- Chemical pre-purification and post-separation at PSI (Paul Scherrer Institute, Villigen, CH);
- Thermoreduction to obtain the metallic Ho target for implantation.
 - ⇒ $\text{Ho}_2\text{O}_3 + 2\text{Y}(\text{met}) \rightarrow 2\text{Ho}(\text{met}) + \text{Y}_2\text{O}_3 @ 2000^\circ\text{C}$
- HOLMES needs $\simeq 200 \text{ MBq}$ of ^{163}Ho .
- 540 mg of 25% enriched Er_2O_3 shipped soon to ILL for irradiation;
 - ⇒ $A(^{163}\text{Ho})_{theo} \simeq 130 \text{ MBq}$ in 50 days (enough for R&D and 512 pixels).

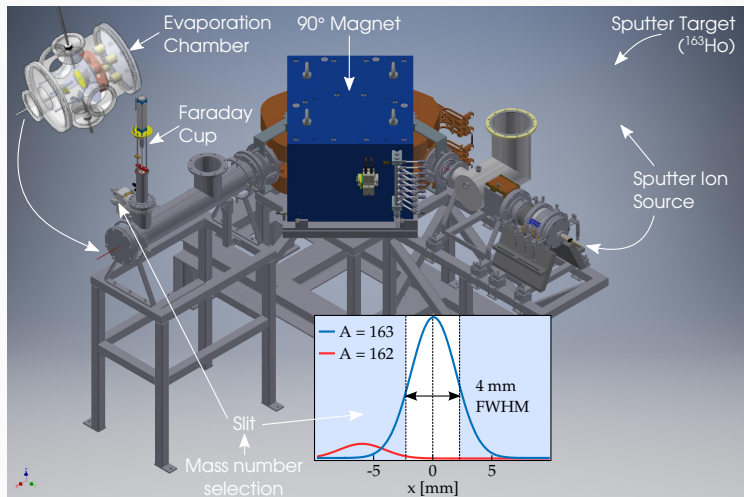

- Designed in collaboration with **Danfysik** (DK). Delivery scheduled from Oct 2016;
- Extraction voltage 30 – 50 kV \Rightarrow (10 – 100) nm implant depth;
- $^{163}\text{Ho}/^{166\text{m}}\text{Ho}$ separation better than 10^5 .



Microcalorimeters

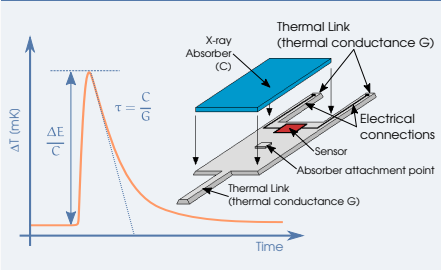

The X-ray microcalorimeter works by sensing the heat generated by X-ray photons when they are absorbed and thermalized in a very low heat capacity element.

- Absorber:
 - Very low thermal capacity (small size, $T < 100$ mK);
 - High stopping power (high Z material).
- Sensor:
 - Si or Ge Thermistors, TES, MMC, ...

Transition Edge Sensor (TES)

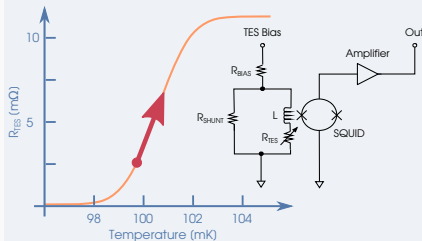

- Exploits strongly temperature-dependent resistance of the superconducting phase transition;
- Low resistance: read out with SQUIDs (Superconducting Quantum Interference Devices);
- Small size, low thermal capacity, excellent energy resolution $\Delta E \simeq 1$ eV @ 1.5 keV;
- Large array and multiplexing (TDM, CDM, FDM and μ wave);



- DC biased TES and SQUID coupled to TES and to a lambda/4-wave resonator circuit in the GHz range;
- Microwave rf-SQUID read out with flux ramp demodulation (common flux line inductively coupled to all SQUIDS);

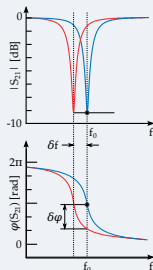
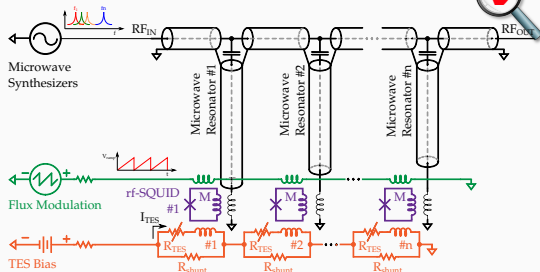

- An event in the absorber increases the temperature and therefore the resistance of the TES;
- Change in TES current \Rightarrow change in the input flux to the SQUID;
- The rf-SQUID transduces a change in input flux into a change of resonance frequency and phase;
- The ramp induces a controlled flux variation in the rf-SQUID, which is crucial for linearizing the response (avoiding need for feedback).
- Large number of superconducting microresonators tuned to different resonance frequencies, all coupled to the same coplanar-waveguide feedline;

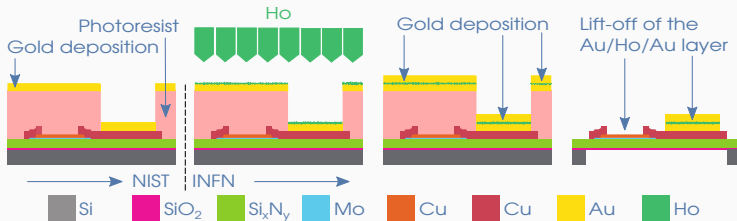

- TES (Transition Edge Sensor) array fabricated at NIST (Boulder, CO, USA);
- ^{163}Ho implantation with Au co-deposition at implanter evaporation chamber [13];
 ⇒ 1 μm Au final layer deposited in-situ after implantation;
- Fabrication completion (Si_2N_3 membrane release), tests in progress at CNR-IFN, Rome;

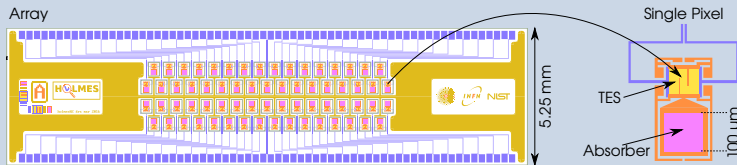

Design of the HOLMES 4×16 linear sub-array for low parasitic L and high implant efficiency [14]

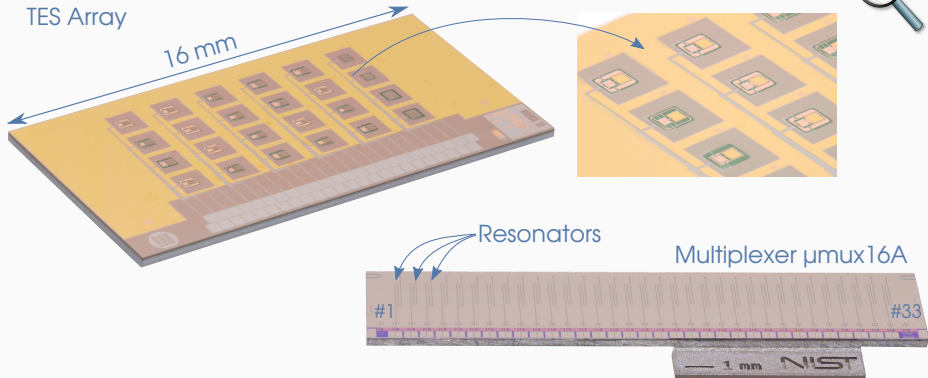

- Production of the first μ Mux multiplexer for high-speed applications at NIST, with 33 microresonators;
- Production of the first 4×6 array prototype at NIST;
- Different Perimeter/Absorber configurations in order to study the detector response;
- Characterization in progress at NIST and INFN Milano-Bicocca;
- Implanting tests starting from 2017 (after the implanter commissioning);

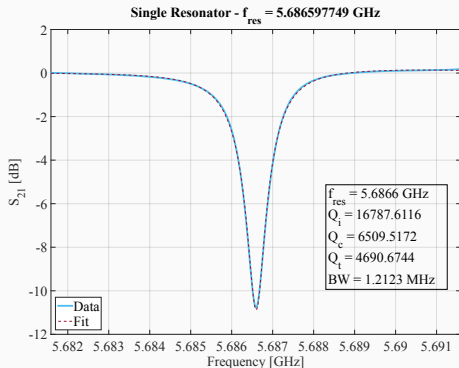
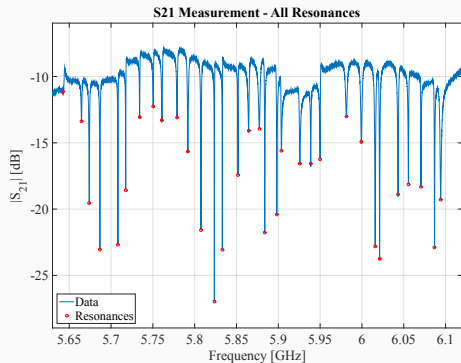

- 31/33 resonators usable for microwave readout;
- Average bandwidth: $BW \simeq 1.6$ MHz \Rightarrow compliant with the HOLMES specifications;
- Average rf-SQUID noise: $n_{\text{SQUID}} \simeq 4 \mu\Phi_0 / \sqrt{(\text{Hz})} \Rightarrow$ not critical for the energy resolution;
- New design for increasing the resonators uniformity in progress;

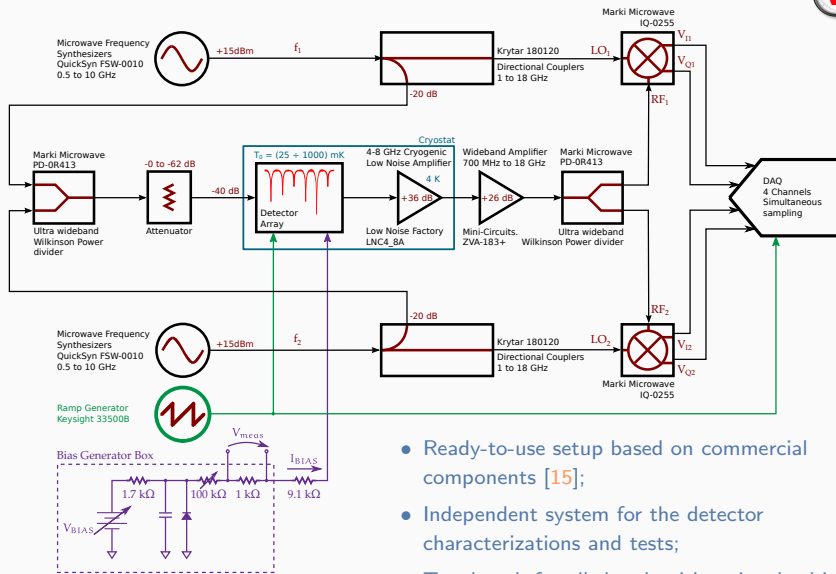

- Ready-to-use setup based on commercial components [15];
- Independent system for the detector characterizations and tests;
- Test bench for all the algorithms involved in the demodulation and preprocessing;

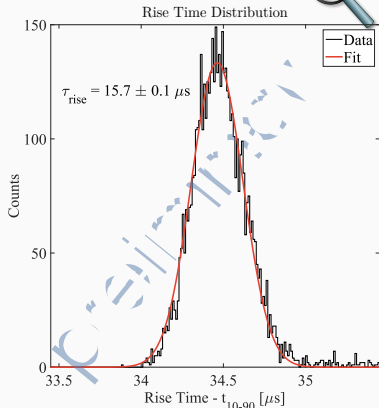
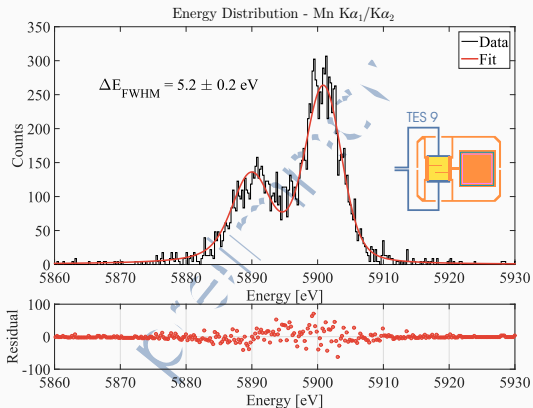

- A class of TES detectors fulfil the HOLMES requirements in terms of energy and time resolution;
- Deep characterization in progress in Milano;
- The best performance TES layout will be implemented in the 4×16 linear array;
- Next detectors array production scheduled in 2017;

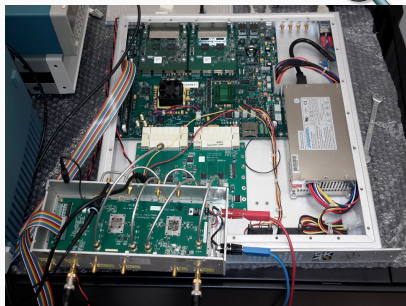
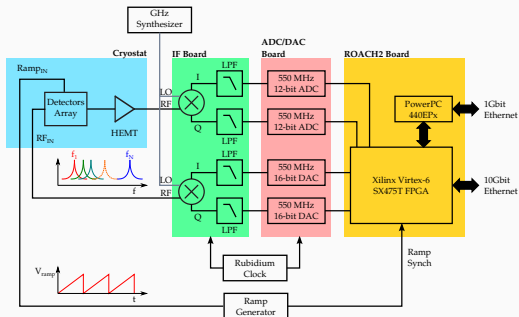

- Open architecture computing hardware ROACH2 (Reconfigurable Open Architecture Computing Hardware) as FPGA process board [16];
- DAC/ADC and IF boards, developed for the MUSIC experiment, as digitizer and up/down converter;
- Complete system composed by around 32 ROACH2+ADC/DAC+IF modules;
- Firmware for 32 channels per ROACH2 in development (Software Defined Radio + flux ramp modulation);
- Encouraging results from tests performed at NIST \Rightarrow 32-Channel readout ready in 2017;



- The measurement of the end point of nuclear beta or electron capture (EC) decays spectra is the only model-independent experimental tool for accessing the absolute neutrino mass;
- The goal of the next future experiments is the sub-eV neutrino mass sensitivity;
- The HOLMES experiment will perform a direct measurement of the neutrino mass by using microcalorimeter with ^{163}Ho -implanted absorber;
- Status:
 - Irradiation in progress at ILL to produce 130 MBq of ^{163}Ho (half of the final required);
 - Implanter designed and delivery scheduled from October 2016;
 - Produced Multiplexer and TES pixel prototype fulfill the HOLMES requirements;
 - A fast 2-channel multiplexing and readout system has been developed;
 - Work on the firmware needed to scale the readout to 1000 pixels has been started.
- Future Plan:
 - Implanter commissioning with first test of ^{163}Ho implanting during the 2017;
 - Development of a 32-channel read-out and multiplexing system;
 - Development and production of the first 4×16 liner array in 2017;
 - At the end of 2017 one month measurement with the developed 4×16 ;
 - 2018 dedicated at the 32×32 array read-out commissioning;

Backup Slides

^{163}Ho : pile-up spectra

Theoretical spectrum measured
by simulated toy experiments

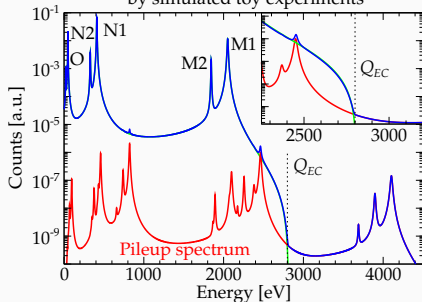

$$Q_{EC} = 2800 \text{ eV}, \Delta E = 2 \text{ eV}, N_{ev} = 10^{14}, f_{pp} = 10^{-4}$$

$$S(E_c) = [N_{ev}(N_{EC}(E_c, m_\nu) + f_{pp} \times N_{EC}(E_c, 0) \otimes N_{EC}(E_c, 0)) + B(E_c)] \otimes R_{\Delta E}(E_c)$$

$$\begin{aligned} S(E_c) &: \text{total theoretical spectrum} \\ N_{EC}(E_c, m_\nu) &: {}^{163}\text{Ho spectrum} \\ B(E) &: \text{background energy spectrum} \\ R_{\Delta E}(E_c) &: \text{detector energy response function} \end{aligned}$$

more details in A. Nucciotti

Eur. Phys. J. C 74, 3161 (2014) [9]

- Pulse pile-up occurs when multiple events arrive within the temporal resolving time of the detector;
- Unresolved pile-up produces a sort of background close to the end-point;
- The ^{163}Ho pile-up events spectrum is quite complex and presents a number of peaks right at the end-point of the decay spectrum;
- To resolve pile-up:
 - Detector with fast signal rise-time τ_{rise} ;
 - Pulse pile-up recovery algorithm



Single and double holes calorimetric spectrum of the EC decay of ^{163}Ho

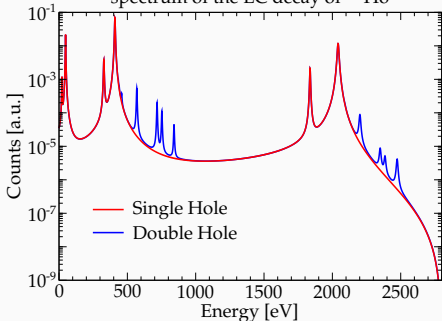

For more details A. Nucciotti

Adv.High Energy Phys. 2016 (2016) 9153024 [11]

- Shake-up and shake-off mechanisms could generate double hole excitations (n-hole excitations possible but less probable);
- Authors do not fully agree on energies and probabilities;
- At the end-point no other effect than altering the overall rate;
- But more complex pile-up spectrum \Rightarrow these higher order transitions cause additional peaks to appear in the end-point vicinity;
 - may be worth keeping f_{pp} smaller than 10^{-4} ;

Theoretical spectrum measured by simulated toy experiments

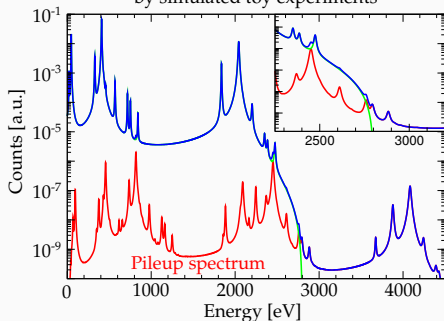

$$Q_{EC} = 2800 \text{ eV}, \Delta E = 2 \text{ eV}, N_{ev} = 10^{14}, f_{pp} = 10^{-4}$$



^{163}Ho properties

- Higher specific activity \Rightarrow Holmium detector not needed;
- Self calibrating \Rightarrow better systematics control;
- Q_{EC} and atomic de-excitation spectrum poorly known;
- Complex pile-up spectrum;

LTD projects with ^{163}Ho :

- ECHo, MMC detectors (Heidelberg, ...) [17];
- NuMECS, TES detectors (LANL, NIST, ...) [18, 19];
- HOLMES, TES detectors (Milano-Bicocca Univ., INFN, NIST, ...) [12];

Common technical challenges:

- Clean ^{163}Ho production;
- ^{163}Ho incorporation;
- Large channel number \Rightarrow high speed MUX;
- Data handling (processing, storage, ...)

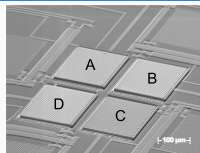

ECHo

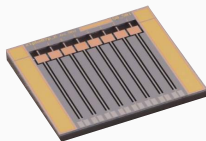

NuMECS

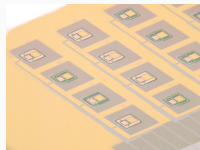

HOLMES

First detector prototype

- low temperature metallic magnetic calorimeters;
- embedding of ^{163}Ho source
 - ions production @ILL (Grenoble, France);
 - ions implantation @ISOLDE-CERN;
- about 0.2 Bq per pixel;
- two pixels simultaneously measured;

Calorimetric spectrum

- rise time $\tau_r \simeq 130$ ns;
- $\Delta E_{FWHM} = 7.6$ eV @ 6 keV;
- non-linearity $<1\%$ @ KeV;
- presently most precise ^{163}Ho spectrum;

Future developments

- EChO-1k proposed for the next years;
- Aimed resolution 5 eV;
- Sensitivity: $m_\nu \simeq 20$ eV after 1 year;

EChO

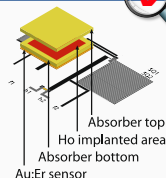
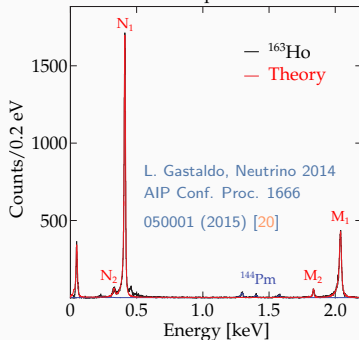
Calorimetric spectrum of ^{163}Ho 

More details in P.C.O Ranitzsch *et al.* [21] and
L. Gastaldo *et al.* [22]



First detector prototype

- Transition Edge Sensors;
- Embedding of ^{163}Ho source
 - proton irradiation of natural Dy @LANL-IPF [?];
 - ^{163}Ho onto thin nanoporous Au foil;
 - nanoporous gold foil deposited on regular Au;
 - absorber obtained by folding and pressing a small piece of the Au foil;
- About 0.1 Bq per pixel;

Calorimetric spectrum

- 40 hours measurement;
- $\Delta E_{FWHM} = 43 \text{ eV} @ \text{M1 Peak}$;
- ^{163}Ho spectrum with limited statistic;

Future developments

- 4×1024 pixel arrays;
- 100 Bq/pixel;
- Sensitivity: $m_\nu < 1 \text{ eV}$ after 1 year;

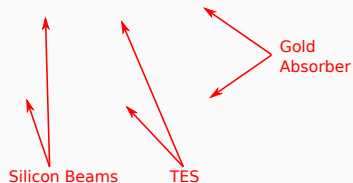

More details in M. P. Croce *et al.* [18] and
G. J. Kunde *et al.* [19]

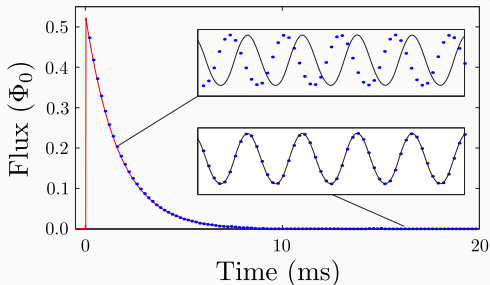
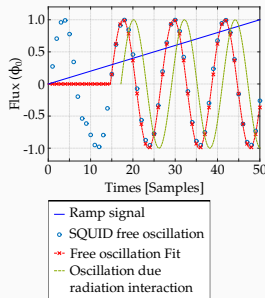

- The signal is reconstructed by comparing the phase shift caused by the interaction of the radiation in the TES, with the free oscillation of the SQUID, when the TES is not biased.
- Each ramp acquisition represents a sample in the reconstructed phase signal: ($f_s \leftrightarrow f_r$);
- Necessary resonator bandwidth per flux ramp: $\Delta f \gtrsim 2n\phi_0 f_r$;
- To avoid cross talk \Rightarrow spacing between resonances: $f_n - f_{n-1} \geq \Delta f$;
- To avoid distortions: $f_r \geq 10/\tau_r$ (potentially reduced by a factor 2);
- Number of flux cycles per ramp: currently $n\phi_0 = 3$, feasible $n\phi_0 = 2$ (possibly 1.1 with different ramp shape).



- [1] J. Angrik et al., “**KATRIN design report 2004**”, *Tech. Rep., Forschungszentrum, Karlsruhe, Germany*, pp. 447–468, 2004.
NPI ASCR Řež, EXP-01/2005, FZKA Scientific Report 7090, MS-KP-0501.
- [2] Michael Sturm, “**Status of the KATRIN experiment with special emphasis on source-related issues**”, 2011, e-print: [arXiv:1111.4773](https://arxiv.org/abs/1111.4773) [hep-ex].
- [3] M. Sisti, et al. (MIBETA Collaboration), “**New limits from the Milano neutrino mass experiment with thermal microcalorimeters**”, *Nuclear Instruments and Methods in Physics Research Section A: Accelerators, Spectrometers, Detectors and Associated Equipment*, vol. 520, no. 13, pp. 125–131, 2004, [doi:10.1016/j.nima.2003.11.273](https://doi.org/10.1016/j.nima.2003.11.273).
- [4] M. Galeazzi, F. Fontanelli, F. Gatti and S. Vitale (MANU Collaboration), “**End-point energy and half-life of the ^{187}re β decay**”, *Physical Review C*, vol. 63, p. 014302, 2000, [doi:10.1103/PhysRevC.63.014302](https://doi.org/10.1103/PhysRevC.63.014302).
- [5] F. Gatti, P. Meunier, C. Salvo and S. Vitale, “**Calorimetric measurement of the ^{163}ho spectrum by means of a cryogenic detector**”, *Physics Letters B*, vol. 398, no. 34, pp. 415–419, 1997, [doi:10.1016/S0370-2693\(97\)00239-6](https://doi.org/10.1016/S0370-2693(97)00239-6).



- [6] A. De Rújula and M. Lusignoli, “**Calorimetric measurements of ^{163}Ho decay as tools to determine the electron neutrino mass**”, *Physics Letters B*, vol. 118, no. 46, pp. 429–434, 1982, doi:10.1016/0370-2693(82)90218-0.
- [7] A. De Rújula and M. Lusignoli, “**Single electron ejection in electron capture as a tool to measure the electron neutrino mass**”, *Nuclear Physics B*, vol. 219, no. 2, pp. 277–301, 1983, doi:10.1016/0550-3213(83)90642-9.
- [8] S. Eliseev et al., “**Direct measurement of the mass difference of ^{163}Ho and ^{163}Dy solves the q -value puzzle for the neutrino mass determination**”, *Physical Review Letters*, vol. 115, no. 6, p. 062501, 2015, doi:10.1103/PhysRevLett.115.062501, e-print: arXiv:1604.04210 [physics.ins-det].
- [9] A. Nucciotti, “**Statistical sensitivity of ^{163}Ho electron capture neutrino mass experiments**”, *The European Physical Journal C*, vol. 74, no. 11, p. 3161, 2014, doi:10.1140/epjc/s10052-014-3161-3, e-print: arXiv:1405.5060 [physics.ins-det].
- [10] Massimiliano Galeazzi, Flavio Gatti, Maurizio Lusignoli, Angelo Nucciotti and Stefano Ragazzi, “**The Electron Capture Decay of ^{163}Ho to Measure the Electron Neutrino Mass with sub-eV Accuracy and Beyond**”, *submitted to Physical Review D*, 2012, e-print: arXiv:1202.4763 [physics.ins-det].



- [11] A. Nucciotti, “**The use of low temperature detectors for direct measurements of the mass of the electron neutrino**”, *Advances in High Energy Physics*, vol. 2016, p. 9153024, 2016, doi:10.1155/2016/9153024, e-print: [arXiv:1511.00968](https://arxiv.org/abs/1511.00968) [hep-ph].
- [12] B. Alpert et al. (HOLMES Collaboration), “**HOLMES - The Electron Capture Decay of ^{163}Ho to Measure the Electron Neutrino Mass with sub-eV sensitivity**”, *The European Physical Journal C*, vol. 75, no. 3, p. 112, 2015, doi:10.1140/epjc/s10052-015-3329-5, e-print: [arXiv:1412.5060](https://arxiv.org/abs/1412.5060) [physics.ins-det].
- [13] A. Orlando, M. Biasotti, V. Ceriale et al., “**Transition-edge sensor arrays of microcalorimeters with ^{163}ho for direct neutrino mass measurements with holmes**”, *Journal of Low Temperature Physics*, vol. 184, no. 3, pp. 892–896, 2016, doi:10.1007/s10909-015-1460-1.
- [14] J. P. Hays-Wehle, D. R. Schmidt, J. N. Ullom and D. S. Swetz, “**Thermal conductance engineering for high-speed tes microcalorimeters**”, *Journal of Low Temperature Physics*, vol. 184, no. 1, pp. 492–497, 2016, doi:10.1007/s10909-015-1416-5.
- [15] A. Giachero et al., “**Development of microwave-multiplexed superconductive detectors for the HOLMES experiment**”, *J. Phys. Conf. Ser.*, vol. 718, no. 6, p. 062020, 2016, doi:10.1088/1742-6596/718/6/062020, e-print: [arXiv:1601.03970](https://arxiv.org/abs/1601.03970) [physics.ins-det].



- [16] Sean McHugh et al., “A readout for large arrays of microwave kinetic inductance detectors”, *Review of Scientific Instruments*, vol. 83, p. 044702, April 2012, doi:10.1063/1.3700812.
- [17] L. Gastaldo et al., “The Electron Capture ^{163}Ho Experiment ECHo”, *Journal of Low Temperature Physics*, vol. 176, no. 5-6, pp. 876–884, 2014, doi:10.1007/s10909-014-1187-4.
- [18] Gerd J. Kunde et al., “Towards Measuring the Neutrino Mass via Holmium Electron Capture Spectroscopy”, 2015.
NuMECS Position Paper published online.
- [19] M. P. Croce et al., “Development of holmium-163 electron-capture spectroscopy with transition-edge sensors”, 2015, e-print: arXiv:1510.03874 [physics.ins-det].
**LOS-ALAMOS-NATIONAL-LABORATORY-REPORT-LA-UR-15-27688,
APPROVED-FOR –UNLIMITED-RELEASE.**
- [20] Loredana Gastaldo, “ ^{163}Ho based experiments”, *AIP Conference Proceedings*, vol. 1666, p. 050001, 2015, doi:10.1063/1.4915556.



- [21] P.C.-O. Ranitzsch et al., “Development of Metallic Magnetic Calorimeters for High Precision Measurements of Calorimetric ^{187}Re and ^{163}Ho Spectra”, *Journal of Low Temperature Physics*, vol. 167, no. 5-6, pp. 1004–1014, 2012, [doi:10.1007/s10909-012-0556-0](https://doi.org/10.1007/s10909-012-0556-0).
- [22] L. Gastaldo et al., “Characterization of low temperature metallic magnetic calorimeters having gold absorbers with implanted ^{163}Ho ions”, *Nuclear Instruments and Methods in Physics Research Section A: Accelerators, Spectrometers, Detectors and Associated Equipment*, vol. 711, pp. 150 – 159, 2013, [doi:10.1016/j.nima.2013.01.027](https://doi.org/10.1016/j.nima.2013.01.027).